

BCH(アジャスタブルバランスカッターヘッド) BCH(Adjustable Balance Cutter Head)
 複刃調整式ヘッド Multiple-blade adjustment type head

荒加工
Rough

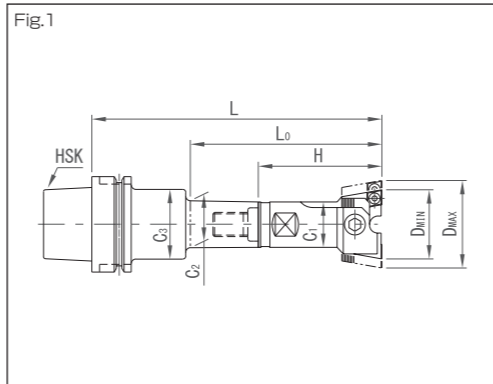

BCH(アジャスタブルバランスカッターヘッド) BCH(Adjustable Balance Cutter Head)
 複刃調整式ヘッド Multiple-blade adjustment type head

荒加工
Rough

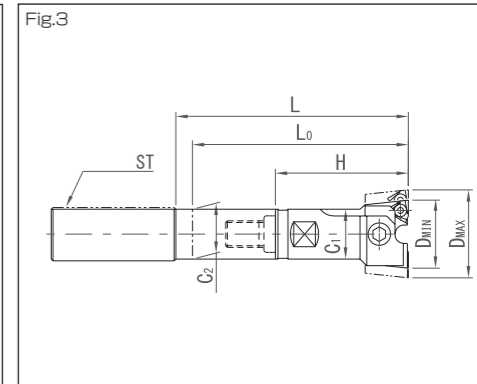
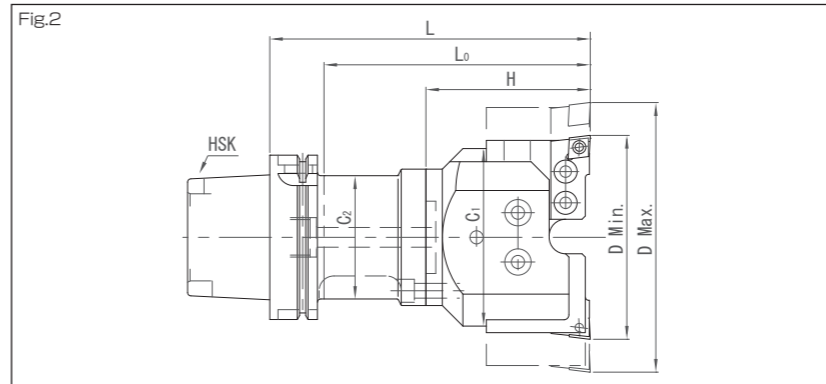

φD 加工径 Machining diameter	Lo 有効加工深さ Effective machining depth	セットコード Set code	図 Fig.	L	C1	C2	C3	H	切刃長さ Cutting edge length					重量 (kg) Weight	セット内容 Set items		ダイヤル 目盛 Dial Calibration
									A型 Type A	T型 Type T	S型 Type S	C型 Type C	CE型 Type CE		シャंक Shank	ヘッド Head	
HSK-A63	100	A63-BCH 28 ■ -135-OH	1	135	23	23	46	65	10	3	7.94	6.35	該当製品 なし N/A	A63-SH23- 70	BCH- 28 ■ -OH	φ 0.1	
		-195-OH		18					-130								
		135		10					-70								
		195		12					-130								
		165		15					-85								
		195		18					-115								
	122	-BCH 41 ■ -165-OH	165	5	9.525	9.525	該当製品 なし N/A	-SH40- 75	BCH- 52 ■ -OH								
		-195-OH	2.2							-105							
		135	3.1							-63							
		165	3.7							-93							
		195	2.9							-100							
		225	3.6							-160							
HSK-A100	100	A100-BCH 28 ■ -165-OH	1	165	23	24	46	65	10	3	7.94	6.35	該当製品 なし N/A	A100-SH23-100	BCH- 28 ■ -OH	φ 0.1	
		-225-OH		12					-100								
		165		12					-160								
		225		15					-85								
		165		18					-105								
		225		18					-165								
	122	-BCH 41 ■ -165-OH	165	5	9.525	9.525	該当製品 なし N/A	-SH57- 83	BCH- 67 ■ -OH								
		-225-OH	3.1							-93							
		161	3.7							-143							
		180	2.9							-203							
		255	3.6							-165							
		255	5.0							-143							
146	-BCH 67 ■ -180-OH	180	5	9.525	9.525	該当製品 なし N/A	-SH63- 83	BCH- 90 ■ -OH									
	-240-OH	5.9							-203								
	206	6.8							-203								
	251	5.5							-83								
	146	6.9							-143								
	266	8.4							-203								
161	-BCH 90 ■ -180-OH	180	2	112	75	-	100	22	6	12.7	該当製品 なし N/A	-SH83- 95	BCH-120 ■ -OH	φ 0.05			
	-240-OH	9.2													-140		
	206	7.6													-185		
	254	9.2													-140		
	254	10.8													-185		
	254	10.8													-185		
ST	95	ST25-BCH 28 ■ -100	3	100	23	24	-	65	10	3	7.94	6.35	該当製品 なし N/A	ST25-SH23- 35	BCH- 28 ■ -OH	φ 0.1	
		-BCH 33 ■ -100		12					-35								
		115		15					-40								
		115		15					-55								
		140		18					-60								
		140		18					-50								
	115	ST32-BCH 28 ■ -120	120	3	23	24	-	65	10	3	7.94	6.35	該当製品 なし N/A	ST32-SH23- 55	BCH- 28 ■ -OH	φ 0.1	
		-BCH 33 ■ -120	12						-55								
		115	15						-60								
		135	18						-50								
		140	18						-60								
		140	18						-50								
115	ST42-BCH 28 ■ -120	120	3	23	24	-	65	10	3	7.94	6.35	該当製品 なし N/A	ST42-SH23- 55	BCH- 28 ■ -OH	φ 0.1		
	-BCH 33 ■ -120	12						-55									
	115	15						-60									
	135	18						-50									
	140	18						-60									
	140	18						-50									
145	-BCH 41 ■ -140	140	5	30	31	-	80	15	5	9.525	9.525	該当製品 なし N/A	-SH30- 60	BCH- 41 ■ -OH	φ 0.05		
	-BCH 52 ■ -140	2.3						-50									
	145	3.8						-53									
	150	4.2						-53									
	150	4.2						-53									
	150	4.2						-53									

(単位: mm)

セットコードについて About Set code.



コードの■部分には刃先タイプを示す文字【A・T・S・C・CE】のいずれかが入ります。ご注文時には必ずご指定ください。
 The ■ part of a code indicates characters specifying a blade type(A,T,S,C,CE).
 Make sure to specify a type when ordering.

A型 Type A ロウ付けブレード Brazed blade

T型 Type T 三角チップブレード Triangular tip mounting blade

S型 Type S 四角チップブレード Square tip mounting blade

C型・CE型 Type C & CE 菱形チップブレード Rhomboid tip mounting blade

- ※NTテーパ・MTテーパの取り扱いもございます。詳細はお問い合わせいただくか、当社ウェブサイトをご覧ください。
 1. ブレード、チップ止めネジ(A型以外)、操作レンチが付属します。チップは付属しません。別途お求めください。
 2. BCH28~52については、オプションで刃先の段差のない製品もご提供できます。ご注文時に「段差なし」とご指定ください。
 3. BCH67~90(C・S型チップのみ)については、オプションでチップ直付スライド型もご提供できます。ご注文時に「チップ直付」とご指定ください。
 4. 出荷時にヘッドとシャंकは組み立てて発送します。組み立てをご希望でない場合は事前にご連絡ください。
 5. STシャंकはクーラントスルー仕様ではありません。

- * NT tapers and MT tapers are also available. For the details, contact us or visit our website.
 1. The blade, tip locking screw(for types other than A), and operating wrench are supplied with the product. Throwaway tips are not supplied with the product and must be purchased separately.
 2. We can provide products with even blade edges for BCH28 to BCH52 as options. Specify "even" when placing an order.
 3. We can provide slide models with direct-mount tips as options for BCH67 to BCH90 (C/S model tips only). Specify "direct-mount tip" when placing an order.
 4. We assemble heads and shanks at shipment. Contact us in advance if you do not wish us to assemble said parts.
 5. ST shank is not coolant-through specification.

P47~48: ブレード・径方向調整ネジ Blade Radial adjustment screw	P51~52: チップ Tip	P55: チップ止めネジ・ブレード締付ボルト・スライドクランプボルト Tip locking screw Blade tightening bolt Slide clamp bolt
P56: チップ用レンチ・エクステンション・リダクション・クーラントダクト Tip wrench Extension Reduction Coolant duct for HSK	P81~84: シャंक Shank	