

BCH (アジャスタブルバランスカッターヘッド) BCH (Adjustable Balance Cutter Head)

複刃調整式ヘッド Multiple-blade adjustment type head

荒加工
Rough

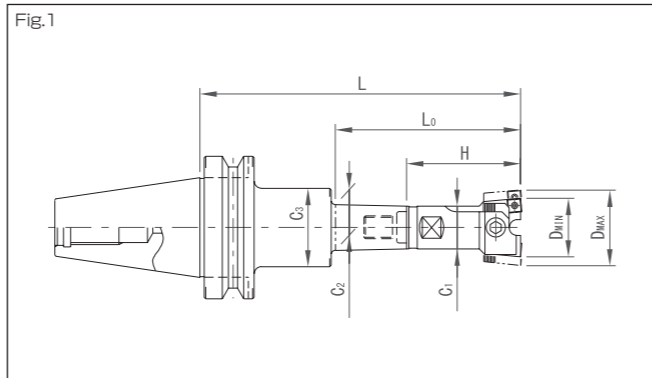

荒加工
Rough

BCH (アジャスタブルバランスカッターヘッド) BCH (Adjustable Balance Cutter Head)

複刃調整式ヘッド Multiple-blade adjustment type head

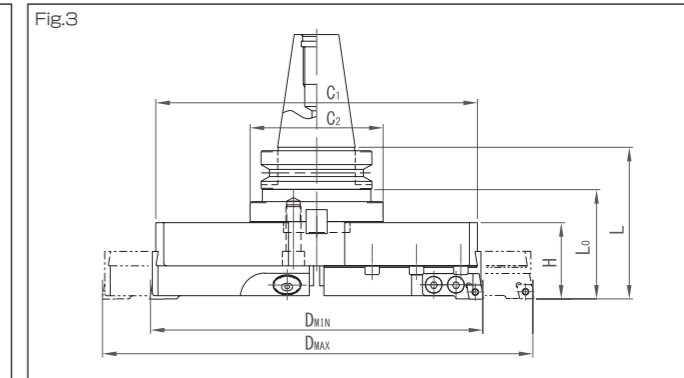
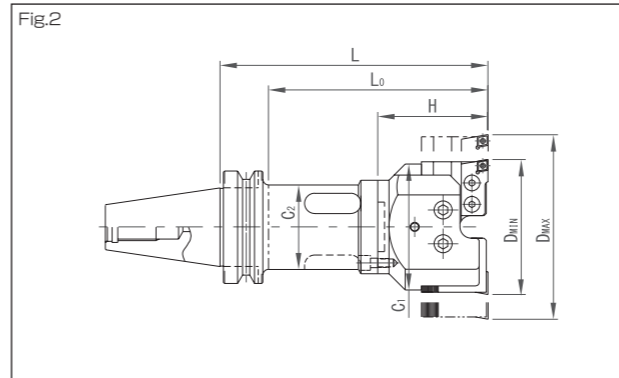

φD 加工径 Machining diameter	Lo 有効加工深さ Effective machining depth	セットコード Set code	図 Fig.	切刃長さ Cutting edge length					重量 (kg) Weight	セット内容 Set items		ダイヤル 目盛 Dial Calibration						
				A 型 Type A	T 型 Type T	S 型 Type S	C 型 Type C	CE 型 Type CE		シャック Shank	ヘッド Head							
BT30	85	BT30-BCH 28 ■ -120-OH	1	120	23	23	23	65	10	3	7.94	6.35	該当製品 なし N/A	0.8	BT30-SH 23- 55	BCH- 28 ■ -OH	φ 0.1	
		12							BCH- 33 ■ -OH									
		15							BCH- 41 ■ -OH									
		18							BCH- 52 ■ -OH									
BT40	100	BT40-BCH 28 ■ -135-OH	1	135	23	24	46	65	10	3	7.94	6.35	該当製品 なし N/A	1.0	BT40-SH 23- 70	BCH- 28 ■ -OH	φ 0.1	
		12							BCH- 33 ■ -OH									
		15							BCH- 41 ■ -OH									
		18							BCH- 52 ■ -OH									
		2.2							BCH- 28 ■ -OH									
		1.4							BCH- 33 ■ -OH									
	122	130	-BCH 41 ■ -165-OH	1	165	30	31	80	15	5	9.525	9.525	12.7	2.2	-SH 30- 85	BCH- 41 ■ -OH	φ 0.1	
			1.4												BCH- 33 ■ -OH			
			2.2												BCH- 28 ■ -OH			
			2.5												BCH- 41 ■ -OH			
			2.8												BCH- 52 ■ -OH			
			3.8												BCH- 67 ■ -OH			
BT50	122	-BCH 52 ■ -165-OH	1	165	40	41	41	90	18	5	9.525	9.525	12.7	4.4	-SH 57- 68	BCH- 52 ■ -OH	φ 0.05	
		4.3													BCH- 67 ■ -OH			
		4.7													BCH- 90 ■ -OH			
		6.0													BCH- 120 ■ -OH			
		6.8													BCH- 120 ■ -OH			
		4.2													BCH- 28 ■ -OH			
	164	165	BT50-BCH 28 ■ -165-OH	2	165	112	50	62	100	22	6	12.7	6.35	該当製品 なし N/A	4.6	BT50-SH 23-100	BCH- 28 ■ -OH	φ 0.1
			4.2													BCH- 33 ■ -OH		
			4.6													BCH- 41 ■ -OH		
			5.0													BCH- 52 ■ -OH		
			5.2													BCH- 67 ■ -OH		
			5.9													BCH- 90 ■ -OH		
BT60	164	-BCH 120 ■ -195-OH	1	195	112	75	100	22	6	12.7	12.7	該当製品 なし N/A	6.5	-SH 83- 95	BCH- 120 ■ -OH	φ 0.05		
		7.1												BCH- 67 ■ -OH				
		8.6												BCH- 90 ■ -OH				
		10.1												BCH- 120 ■ -OH				
		7.3												BCH- 28 ■ -OH				
		8.8												BCH- 33 ■ -OH				
	224	197	-BCH 160 ■ -180-OH	2	180	148	95	90	22	6	12.7	12.7	該当製品 なし N/A	10.3	-SH 160- 90	BCH- 160 ■ -OH	φ 0.1	
			10.0												BCH- 41 ■ -OH			
			11.6												BCH- 52 ■ -OH			
			13.1												BCH- 67 ■ -OH			
			13.5												BCH- 90 ■ -OH			
			15.5												BCH- 120 ■ -OH			
300	95	BT50-M-BCH300 ■ -140	3	140	290	-	73	該当製品 なし N/A	6	12.7	12.7	該当製品 なし N/A	16.0	BT50-SH300- 67	M-BCH300 ■	φ 0.03		
		19.3												M-BCH390 ■				
		21.3												M-BCH480 ■				
		25.2												M-BCH300 ■				
		28.5												M-BCH390 ■				
		30.5												M-BCH480 ■				

(単位: mm)

セットコードについて About Set code.

ターノ No. Taper No. BCHヘッド BCH Head 刃先 Shape 寸法 Length

BT50 - BCH28 ■ - 100 - OH

コードの■部分には刃先タイプを示す文字【A・T・S・C・CE】のいずれかが入ります。ご注文時には必ずご指定ください。
The ■ part of a code indicates characters specifying a blade type(A,T,S,C,CE). Make sure to specify a type when ordering.

A型 Type A ロウ付けブレード Brazed blade

BCH28A ~ BCH52A BCH67A ~ BCH120A

T型 Type T 三角チップブレード Triangular tip mounting blade

BCH28T ~ BCH52T BCH67T ~ BCH120T

S型 Type S 四角チップブレード Square tip mounting blade

BCH28S ~ BCH52S BCH67S ~ BCH120S

C型・CE型 Type C & CE 菱形チップブレード Rhomboid tip mounting blade

BCH28C ~ BCH52C BCH67C/CE ~ BCH120C/CE

- ブレード、チップ止めネジ(A型以外)、操作レンチが付属します。チップは付属しません。別途お求めください。
- BCH28~52については、オプションで刃先の段差のない製品もご提供できます。ご注文時に「段差なし」とご指定ください。
- BCH67~90(C・S型チップのみ)については、オプションでチップ直付スライド型もご提供できます。ご注文時に「チップ直付」とご指定ください。
- 出荷時にヘッドとシャックは組み立てて発送します。組み立てをご希望でない場合は事前にご連絡ください。
- M-BCHはクーラントスルー仕様ではありません。

- The blade, tip locking screw (for types other than A), and operating wrench are supplied with the product. Throwaway tips are not supplied with the product and must be purchased separately.
- We can provide products with even blade edges for BCH28 to BCH52 as options. Specify "even" when placing an order.
- We can provide slide models with direct-mount tips as options for BCH67 to BCH90 (C/S model tips only). Specify "direct-mount tip" when placing an order.
- We assemble heads and shanks at shipment. Contact us in advance if you do not wish us to assemble said parts.
- M-BCH is not coolant-through specification.

P47~48: ブレード・径方向調整ネジ Blade Radial adjustment screw P51~52: チップ Tip
 P55: チップ止めネジ・ブレード締付ボルト・スライドクランプボルト Tip locking screw Blade tightening bolt Slide clamp bolt
 P56: チップ用レンチ・エクステンション・リダクション Tip wrench Extension Reduction P81~84: シャック Shank