

シャंक Shank  
各種テーパ規格 Various taper standards

Shank シャंक  
Various taper standards 各種テーパ規格

BT寸法表 BT Dimension Table

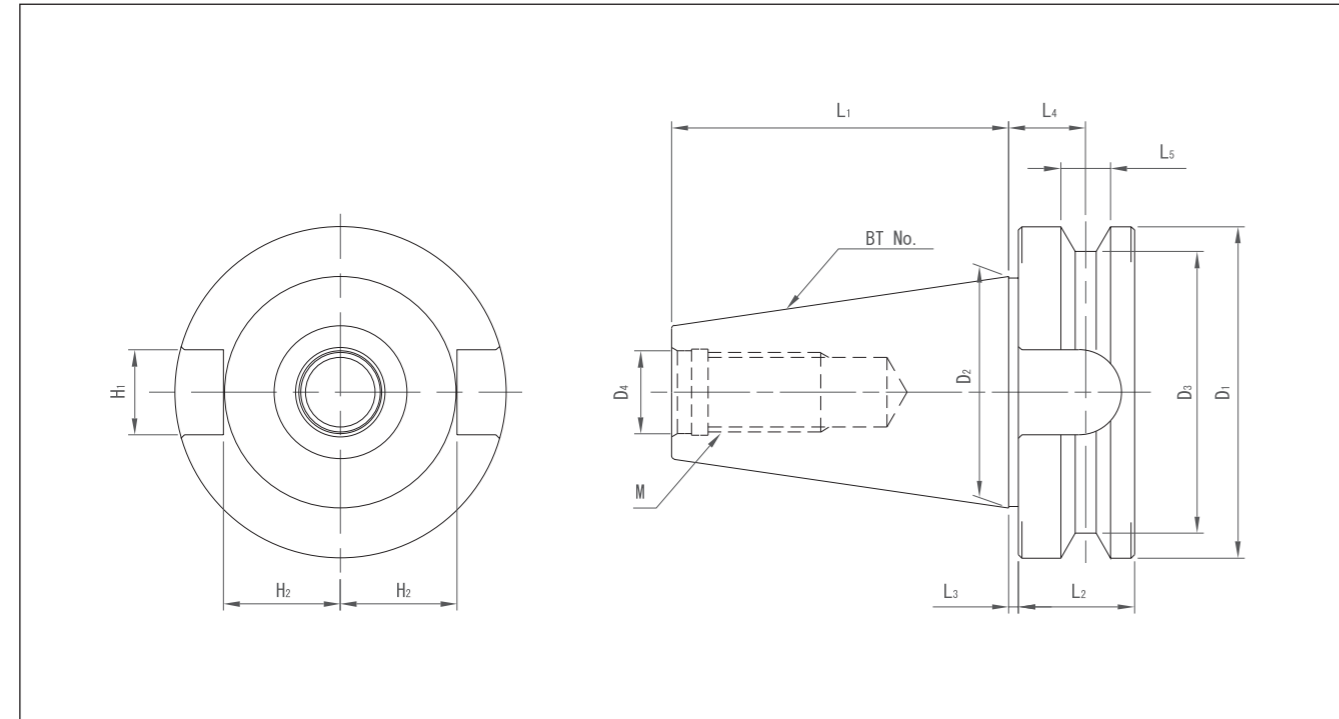

(単位: mm)

BT No.	D <sub>1</sub>	D <sub>2</sub>	D <sub>3</sub>	D <sub>4</sub>	L <sub>1</sub>	L <sub>2</sub>	L <sub>3</sub>	L <sub>4</sub>	L <sub>5</sub>	H <sub>1</sub>	H <sub>2</sub>	M
BT30	46	31.75	38	12.5	48.4	20	2	13.6	8	16.1	16.3	M12
BT40	63	44.45	53	17	65.4	25		16.6	10		22.6	M16
BT50	100	69.85	85	25	101.8	35	3	23.2	15	25.7	35.3	M24
BT60	155	107.95	135	31	161.8	45		28.2	20		60.1	M30

NT寸法表 NT Dimension Table

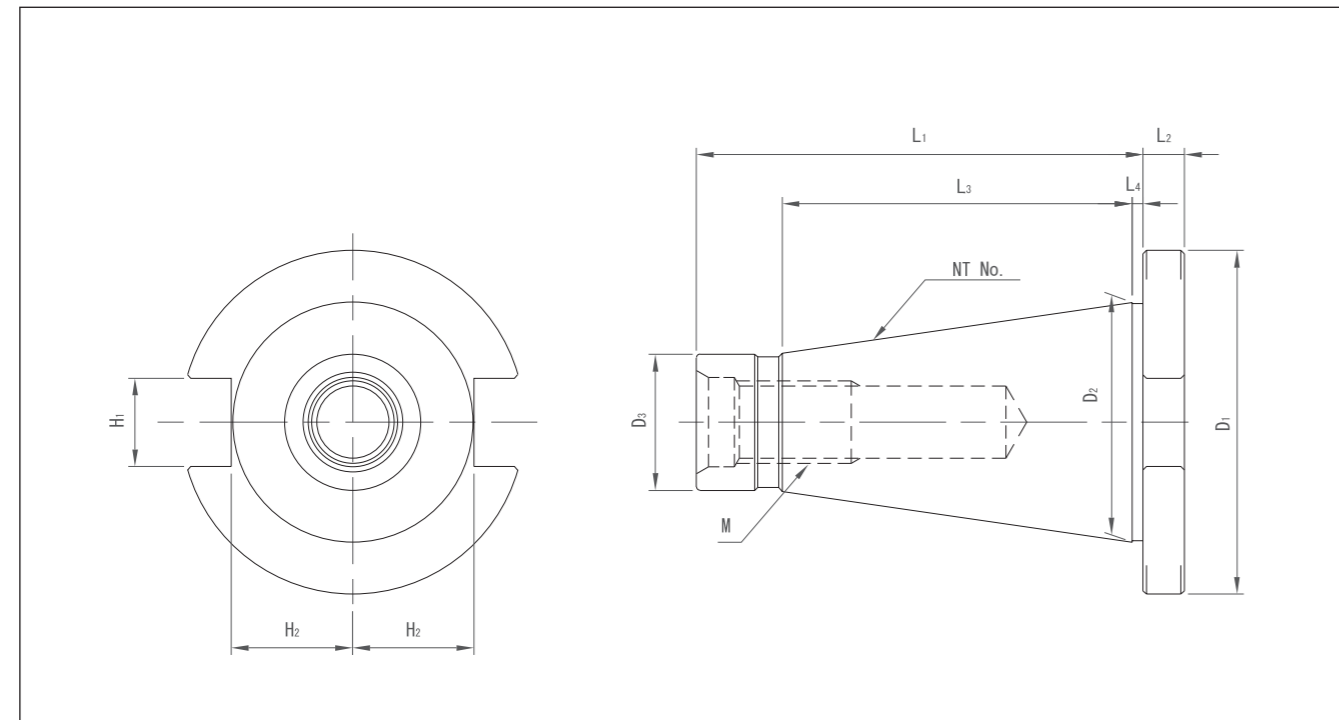

(単位: mm)

NT No.	D <sub>1</sub>	D <sub>2</sub>	D <sub>3</sub>	L <sub>1</sub>	L <sub>2</sub>	L <sub>3</sub>	L <sub>4</sub>	H <sub>1</sub>	H <sub>2</sub>	M	
										メートル Metric	ユニファイ Unified
NT30	46	31.75	17.4	70	10	48.4	1.6	16.1	16.2	M12	1/2-13UNC
NT40	63	44.45	25.3	95					22.5	M16	5/8-11UNC
NT50	100	69.85	39.6	130	12	101.8	3.2	25.7	35.3	M24	1" - 8UNC
NT60	155	107.95	60.2	210					60	M30	1 1/4" - 7UNC

MT寸法表(タング式) MT Dimension Table(Tongue Type)

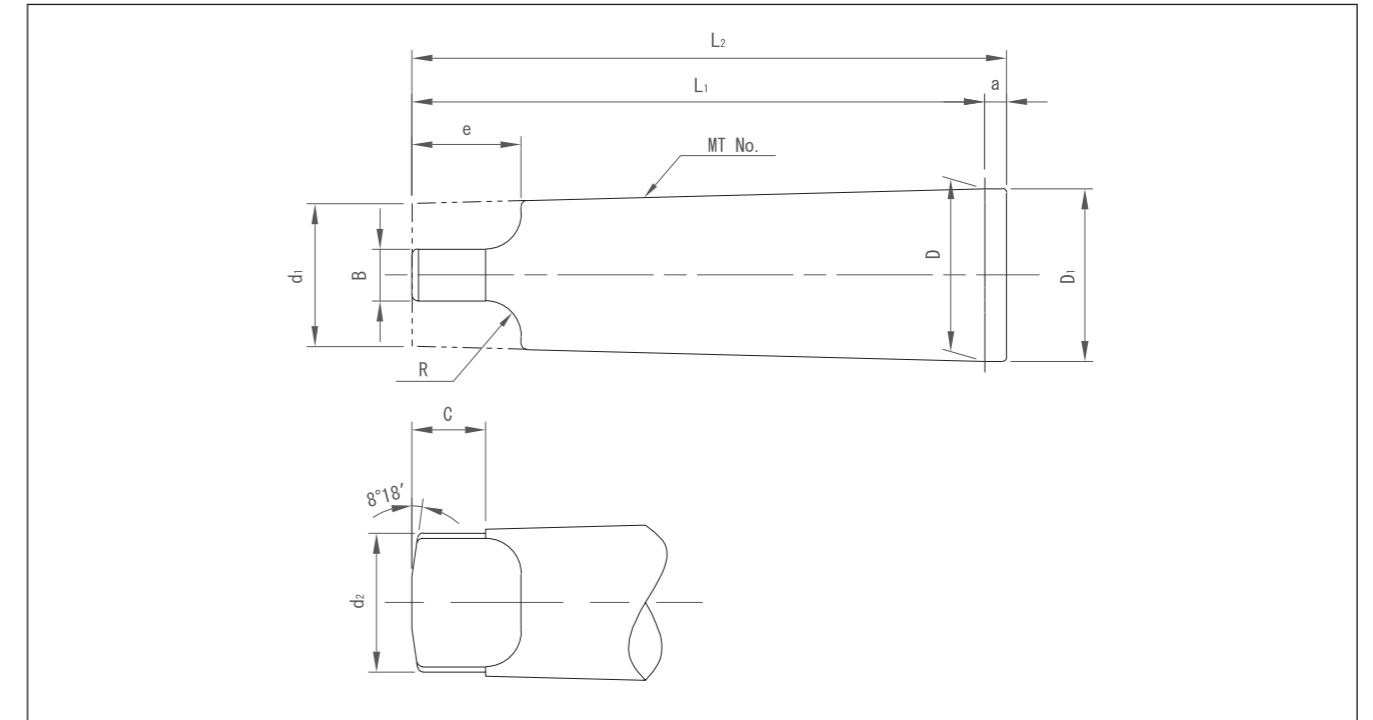

(単位: mm)

MT No.	D	a	D <sub>1</sub>	d <sub>1</sub>	d <sub>2</sub> (最大) (Max.)	L <sub>1</sub> (最大) (Max.)	L <sub>2</sub> (最大) (Max.)	B	C	e (最大) (Max.)	R (最大) (Max.)
MT2	17.780	5	18.0	14.0	13.5	75.0	80	6.3	10	16	6
MT3	23.825		24.1	19.1	18.5	94.0	99	7.9	13	20	7
MT4	31.267	6.5	31.6	25.2	24.5	117.5	124	11.9	16	24	8
MT5	44.399		44.7	36.5	35.7	149.5	156	15.9	19	29	10
MT6	63.348		8	63.8	52.4	51.0	210.0	218	19	27	40
MT7	83.058	10	83.6	68.2	66.8	286.0	296	28.6	35	54	19

HSK寸法表 HSK Dimension Table

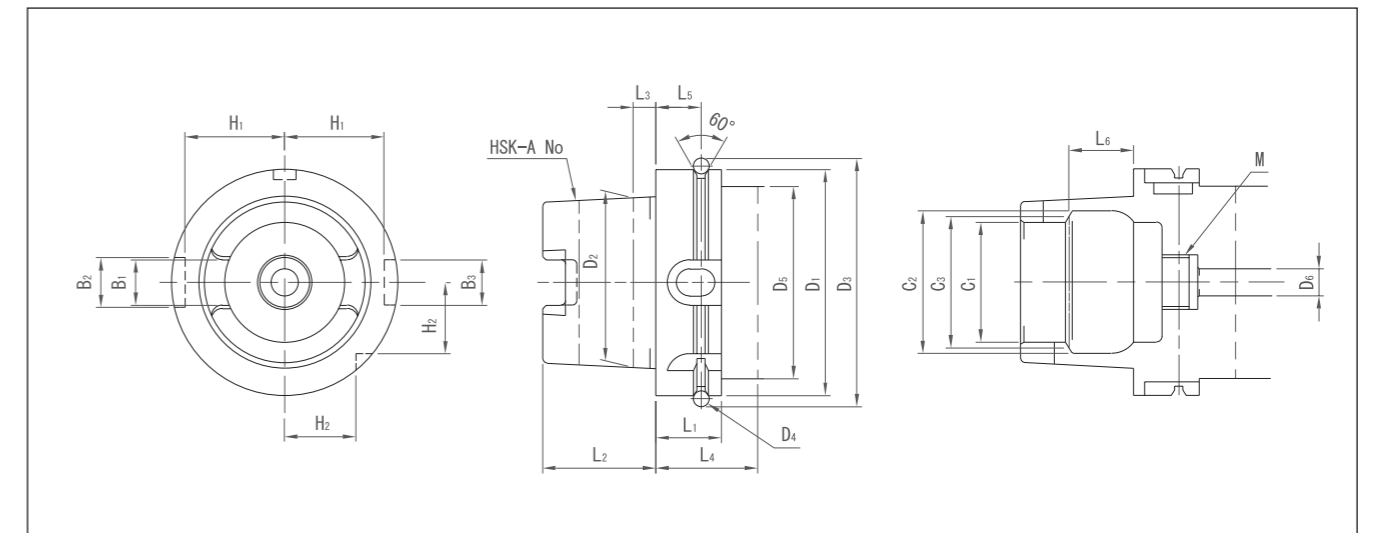

(単位: mm)

HSK No.	D <sub>1</sub>	D <sub>2</sub>	D <sub>3</sub>	D <sub>4</sub>	D <sub>5</sub> (最大) (Max.)	D <sub>6</sub> (最大) (Max.)	L <sub>1</sub>	L <sub>2</sub>	L <sub>3</sub>	L <sub>4</sub> (最小) (Min.)	L <sub>5</sub>	L <sub>6</sub>
HSK-A 63	63	48	72.3	7	53	8.4	26	32	6.3	42	18	18.13
HSK-A100	100	75	109.75		85	12	29	50	10	45	20	28.56

(単位: mm)

HSK No.	C <sub>1</sub>	C <sub>2</sub>	C <sub>3</sub>	B <sub>1</sub>	B <sub>2</sub>	B <sub>3</sub>	H <sub>1</sub>	H <sub>2</sub>	M
HSK-A 63	34	40	37	12.54	18	16	26.5	20	M18 × 1.0
HSK-A100	53	63	58	20.02	22	20	44	31.5	M24 × 1.5