

# モーリスターパーホルダA型(MTA) MORSE TAPER HOLDER TYPE A(MTA)

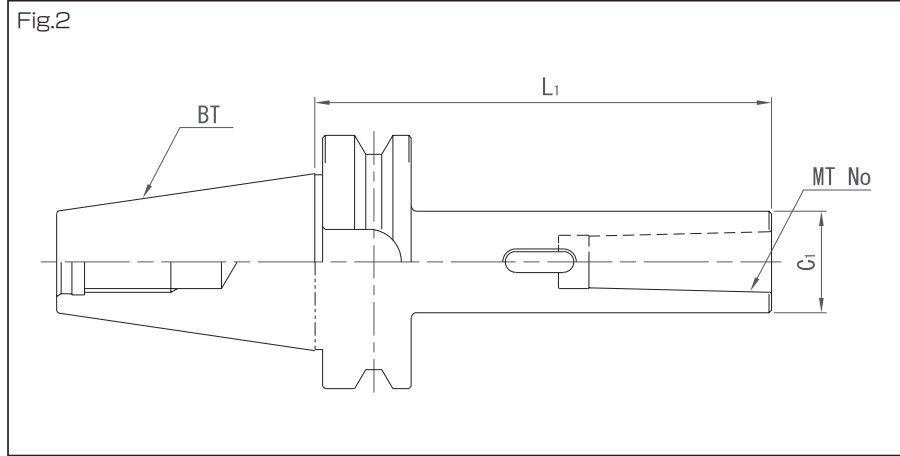

(単位 : mm)

コード Code	図 Fig.	内テーパ Internal taper	L1	C1	重量 (kg) Weight
BT40-MTA1-	1	MT1	45	25	1.0
	2		120		1.3
			180		1.6
-MTA2-	1	MT2	45	32	1.0
	2		120		1.6
			180		2.0
-MTA3-	1	MT3	75	40	1.0
	2		135		1.7
			180		2.2
-MTA4-	1	MT4	90	50	1.1
	2		165		2.6
BT50-MTA1-	1	MT1	45	25	3.9
	2		120		4.2
			180		4.3
-MTA2-	1	MT2	45	32	3.9
	2		135		4.3
			180		4.6
-MTA3-	1	MT3	45	40	3.8
	2		150		4.6
			180		4.9
-MTA4-	1	MT4	75	50	3.9
	2		180		5.4
-MTA5-	1	MT5	105	65	4.5
	2		210		7.2

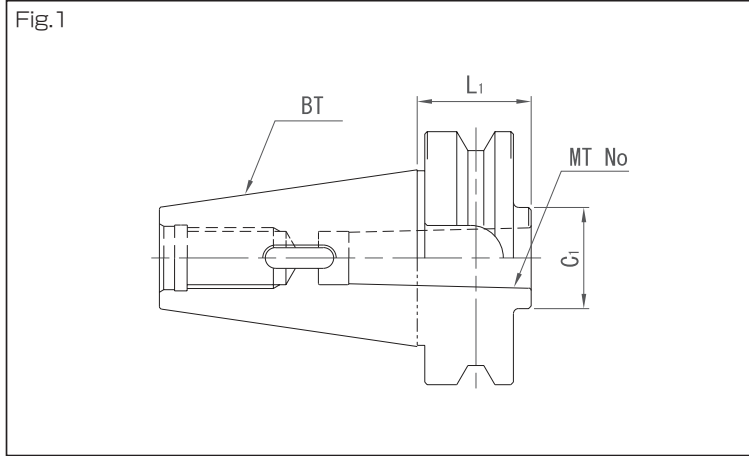

1. 本製品はTMT規格に準じています。
  2. ドリルは付属していません。また、弊社では取り扱っておりません。
  3. プルスタッドは付属しておりません。別途お求め下さい。
- 1.This product conforms to TMT standards.
  - 2.Drills are not supplied with the product and we do not handle such products.
  - 3.Pull stud do not come with the product and must be purchased separately.

# モールステーパホルダB型(MTB) MORSE TAPER HOLDER TYPE B(MTA)

Fig.1

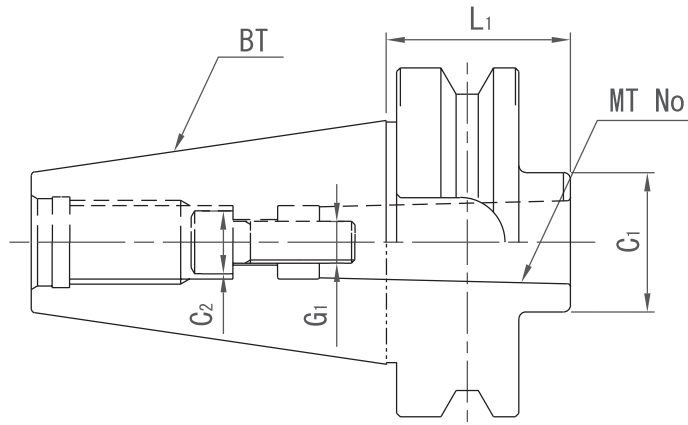
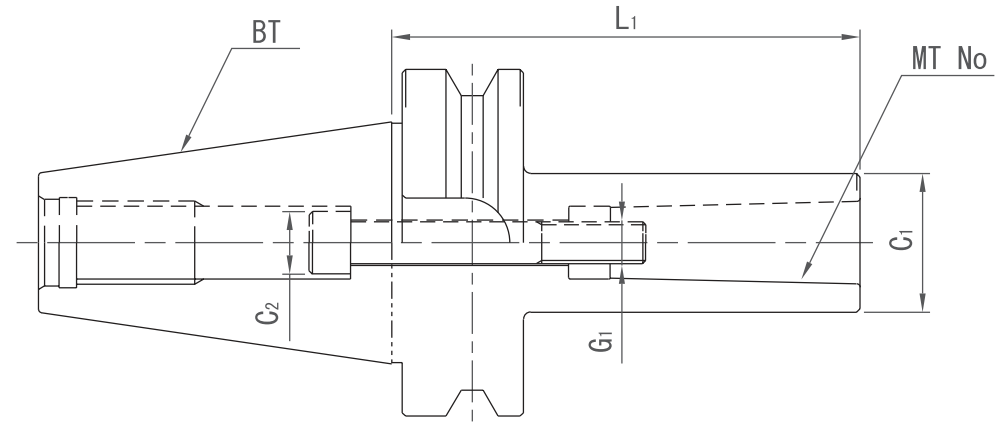

Fig.2



(単位：mm)

コード Code	図 Fig.	内テーパ Internal taper	L1	C1	C2	G1	重量 (kg) Weight
BT40-MTB1- 45	1	MT1	45	25	10	M6	1.0
- 90	2		90				1.1
-MTB2- 45	1	MT2	45	32	13.5	M10	1.0
-120	2		120				1.3
BT50-MTB1- 45	1	MT1	45	25	10	M6	4.0
-105	2		105				4.2
-MTB2- 45	1	MT2	45	32	16	M10	4.0
-120	2		120				4.3
-MTB3- 60	1	MT3	60	40	18	M12	4.0
-135	2		135				4.5
-MTB4- 75	1	MT4	75	50	20.5	M16	4.1
-150	2		150				4.8

1. 本製品はTMT規格に準じています。
2. ドリルは付属していません。また、弊社では取り扱っておりません。
3. プルスタッドは付属しておりません。別途お求め下さい。

1. This product conforms to TMT standards.
2. Drills are not supplied with the product and we do not handle such products.
3. Pull stud do not come with the product and must be purchased separately.

